

IT'S ALL A MATTER OF TIMING: CIRCUIT BREAKER MOTION TESTS - PART I

By Fouad Brikci, Ph.D., Zensol Automation Inc.; Emile Nasrallah, P.Eng., Circuit Breaker Specialist

1 THE DISPLACEMENT CURVE

1.1 Description

During circuit breaker timing tests, the measurement of the operation times from the first appearance of the order on the command coil to the switching of the main contact, is recorded with a timing instrument, such as the ZENSOL CBA32-P.

This measurement offers precious information on the state of the circuit breaker and allows, in most cases, the precise verification of the presence or absence of anomalies. But this information does not reveal all the secrets of the circuit breaker. Other important information remains hidden from view.

Whenever it is possible, a point-by-point measurement of the movement of the internal components of the circuit breaker, from the beginning of the movement until it comes to a complete stop, traces a curve called a DISPLACEMENT CURVE.

While the main contact timing curve gives the moment when the movement starts and the moment when the contact switches over, the information contained in the displacement curve is interesting because it allows us to follow the entire movement from beginning to end.

1.2 Operation on opening

An example of a displacement curve for an Open operation is shown in Fig. 1.2, superimposed on an opening timing curve for the main contact (in red).

Even if the general shape of the curve is the first characteristic to check, three Zones (circled in Fig. 1.2) merit particular attention.

1. Zone A: the beginning of the movement.
2. Zone B: contact separation.
3. Zone C: from the beginning of the deceleration to the final resting position.

1.2.1 Zone A: the beginning of the movement

This is where the movement starts. It is extremely important to know if the

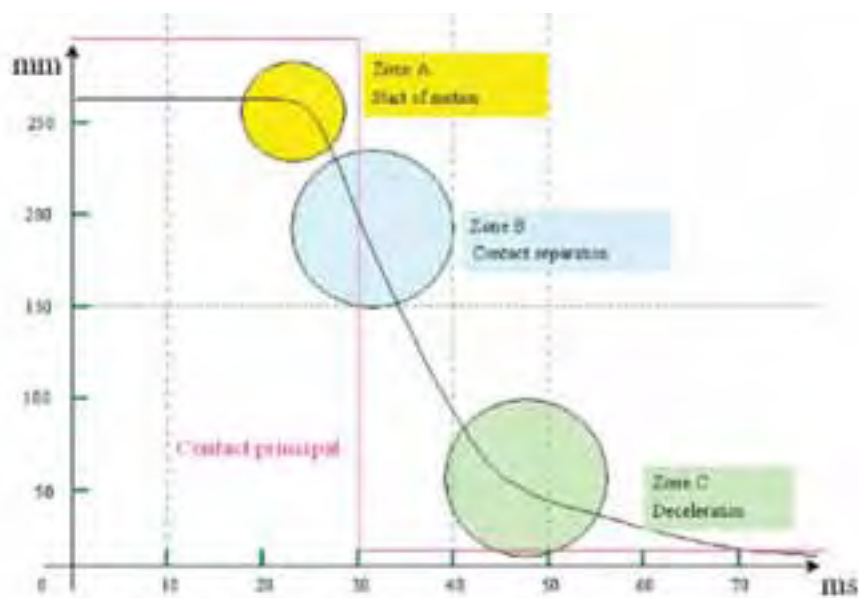

Fig 1.2 Displacement curve on Open operation

movement has begun at the right moment. For example, a delay with respect to the reference specification means an electrical problem exists, if the coil is not excited on time, or a mechanical problem may exist between the command mechanism where the movement is triggered and the mobile contact of the breaker itself.

1.2.2 Zone B: contact separation

This is where the main contacts separate from each other. At this exact instant, the arc begins to form and the breaker implements its measures to extinguish it. The separation speed becomes an important and primordial factor in order to succeed in breaking the circuit.

The method for calculating the average velocity in this zone depends on the breaker designer. Only the designer may determine the calculation method and establish the reference specification.

1.2.3 Zone C: deceleration

This is where the movement decelerates until the circuit breaker's mobile contact comes to a complete stop.

The amount of energy required in the breaking process is proportional to the intensity of the current being interrupted. Once the current has been interrupted and the arc has been extinguished, the energy developed is quite excessive.

Effective means of damping are put into action to absorb this excess energy and thus reduce the risk of damaging the internal components of the circuit breaker. The analysis of this zone makes it possible to determine if the damping is optimal, which means the movement is stopped gradually.

Insufficient damping, or underdamping, allows the moving parts to undergo shocks, which causes severe damage.

A sudden damping, where the kinetic energy developed by the moving parts of the breaker is absorbed over very little time, causes damage similar to underdamping. This phenomenon is called overdamping.

1.3 Operation on closing

An example of a displacement curve for a Close operation is shown in Fig. 1.3, superimposed on a timing curve for the main contact (in red).

Even if the general shape of the curve is the first characteristic to check, three Zones (circled in Fig. 1.3) merit particular attention.

Zone A: the beginning of the movement.

Zone B: contact closing

Zone C: from the beginning of the deceleration to the final resting position.

1.3.1 Zone A: the beginning of the movement

As is the case for the opening displacement curve, this is where the movement starts, and it is very important to know if the movement started at the right place.

1.3.2 Zone B: contact closing

This is where the main contacts come into contact. In this zone, also called the pre-arc zone, as the contacts come closer to each other, the dielectric, as a function of the separation distance, becomes insufficient and a pre-arc current forms within an arc, the duration of which is a function of the speed of the contacts.

Thus, contact velocity is an important factor in limiting premature wear of the contacts.

As is the case for the opening operation, the method for calculating the average speed in this zone is also determined by the designer of the breaker. Only the designer may determine this calculation method and establish the reference specification.

1.3.3 Zone C: deceleration

This is where the movement slows down to a complete stop of the breaker's mobile contacts.

The energy involved in the closing process is less than that developed in the breaking process, but it is nonetheless quite considerable.

Excess energy is translated into an overtravel which, if it exceeds tolerances, may cause severe damage to the device.

1.4 Velocity curve

A velocity curve is calculated by the derivative of the displacement curve, using, for example, the CBA Win analysis software. The velocity curves gives the speed as a function of time, which gains new information on the dynamic behavior of the circuit breaker.

1.5 Acceleration curve

In the same manner, an acceleration curve can be traced, as the derivative of the velocity curve, again using the CBA Win analysis software, which gives additional useful data.

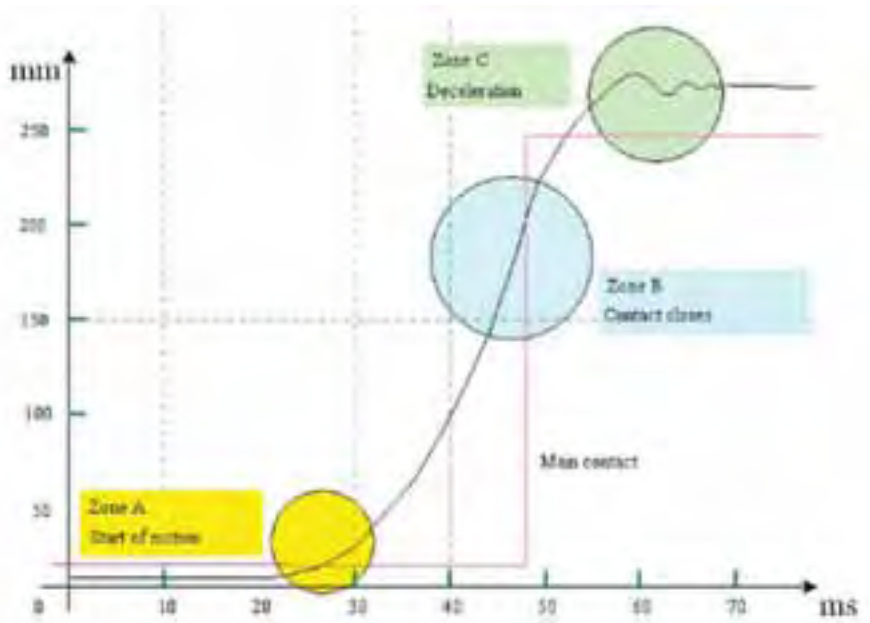
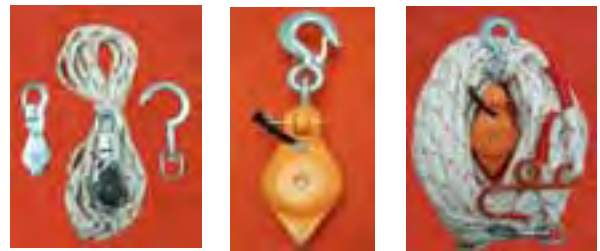

Fig 1.3 Displacement curve for Close operation

displacement transducer is used to sense the movement of the mobile contact. The CBA Win software processes the data, traces the displacement curve and performs the various veloc-



Handline & Block Sets



High Quality - Lower Price



800-710-2976

2 PERFORMING THE MEASUREMENT

To record the displacement curve, some type of assembly is needed between the ZENSOL CBA-32P and the breaker. A

ity calculations. To understand the process, a summary description of the transducer, the breaker and the CBA-32P follows.

2.1 Displacement transducer

2.1.1 Description

The displacement transducer, in its most elementary form, consists of a fixed part and a mobile part. The mobile part is attached to the mobile contact of the breaker under test, and moves with the contacts, while the fixed part acts as a reference.

Several types of transducers are available on the market. Their differences reside in the method used to identify the relative value against the reference value. Some examples of transducers are:

- Magnetic transducer
- Optical transducer
- Resistive transducer
- Etc.

The resistive transducer, which is the most popular, will be described in detail. This type of transducer is composed of a resistor and a cursor that moves along the length of this resistor. There are two types of resistive transducers:

- Linear displacement transducer, or linear transducer (fig. 2.11a)
- Rotary displacement transducer, or rotary transducer (fig.2.11b)

The difference lies in the physical layout of the reference resistor and in the way the cursor moves.

For the linear transducer, the displacement of the cursor is linear, in a straight line whereas, for the rotary transducer, the displacement is a rotation around an axis.

2.1.2 Operation

The transducer is solidly attached to the breaker support, while the mobile cursor is solidly attached to the control arm of the mobile contact.

A known, fixed voltage source (E) is connected to terminals (1) and (3). When the breaker is in the CLOSED position, the voltage read between terminals (2) and (3) is (V_1). As the mobile contact moves toward the OPEN position, the measured voltage (V_t) between terminals (2) and (3) decreased as a function of time, down to value (V_2), which is less than (V_1), when the breaker has completely stopped.

2.2 Circuit Breaker

2.2.1 Description

A high-voltage circuit breaker consists of two main parts:

1. Active section (electrical power)
2. Command section

The active section must make or break the power current in the high-voltage circuit where the breaker is installed. The command section must develop the necessary energy to perform these operations.

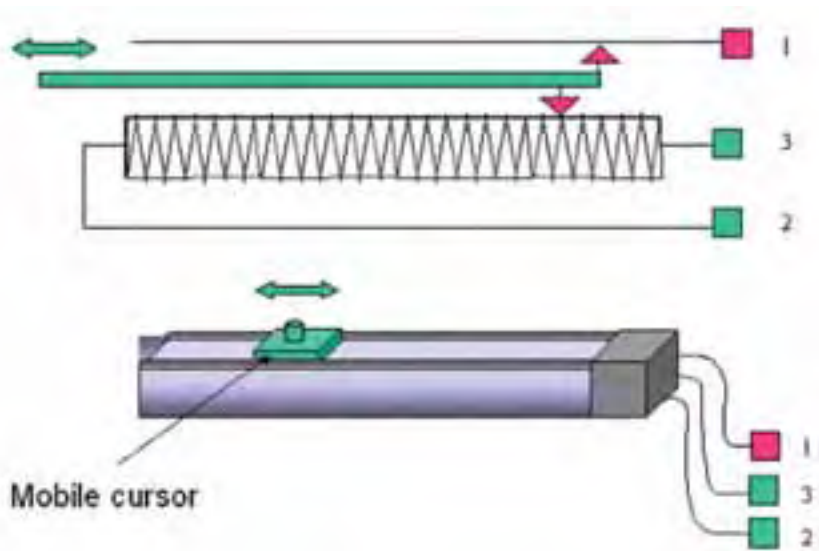

Fig 2.11a - Linear displacement transducer

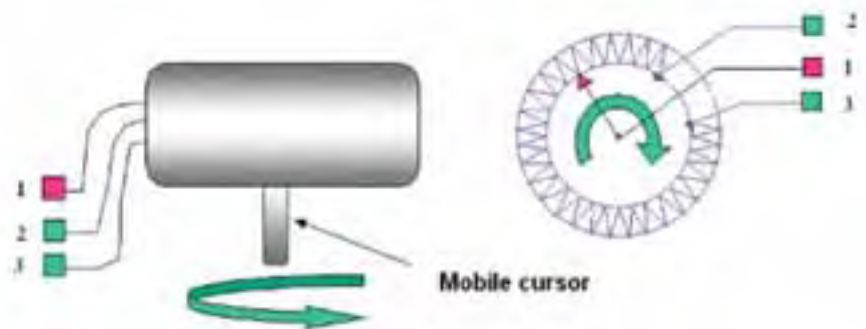

Fig 2.11b - Rotary displacement transducer

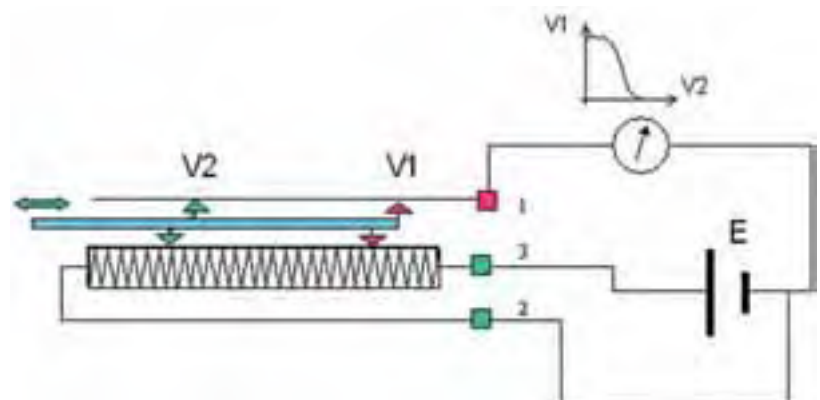

Fig. 2.12 Operation of a displacement transducer

The link between the command and active sections is usually an insulating rod, shown in red in the schematic in Fig. 2.21.

2.2.2 Electrical power section

This part generally constitutes three phases of equal size. Each phase, in turn, is composed of a fixed contact assembly and a mobile contact assembly. When the two assemblies are in contact, it is said that the breaker is CLOSED, so current flows through the power circuit.

To interrupt the flow of current in the power circuit, the mobile contact assembly is mechanically moved away from the fixed contact assembly and stopped at a distance that is sufficient to ensure electrical isolation.

2.2.3 Command section

This section has the task of creating the energy required to perform the mechanical operation of the breaker, for both Open and Close operations.

Three types of commands are often used in high-voltage circuit breakers:

- Pneumatic
- Hydraulic
- Mechanical spring

2.2.3.1 Pneumatic command

Usually found on compressed air circuit breakers. This type uses compressed air as a dielectric medium and uses piston-type mobile contacts.

A series of valves activated in a precise sequence allows the application of air pressure on one side of the piston, which causes the latter to move through the action of the pressure difference between the opposing sides of the piston. The movement of the mobile contacts is generally not accessible in this type of circuit breaker, making the use of conventional transducers almost impossible.

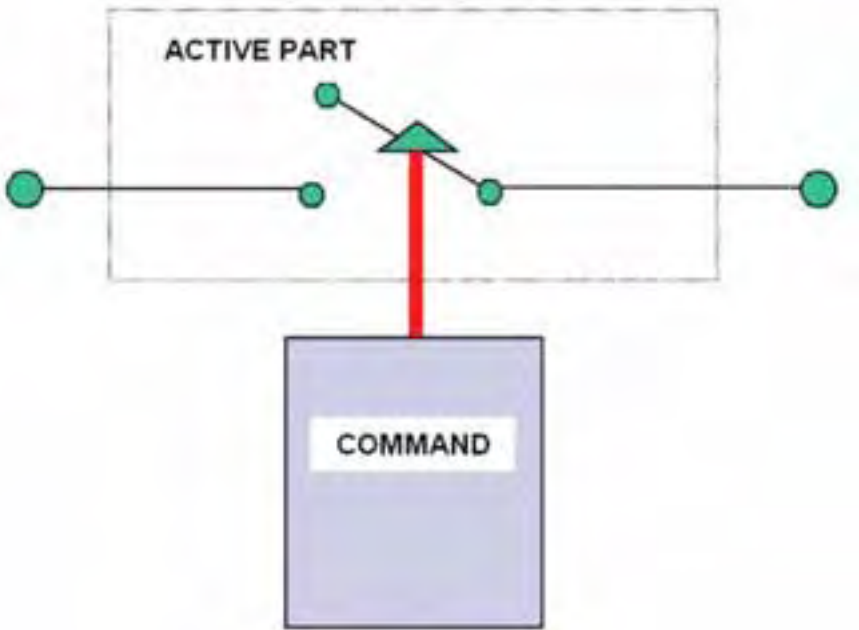

Fig. 2.21 Circuit breaker principle

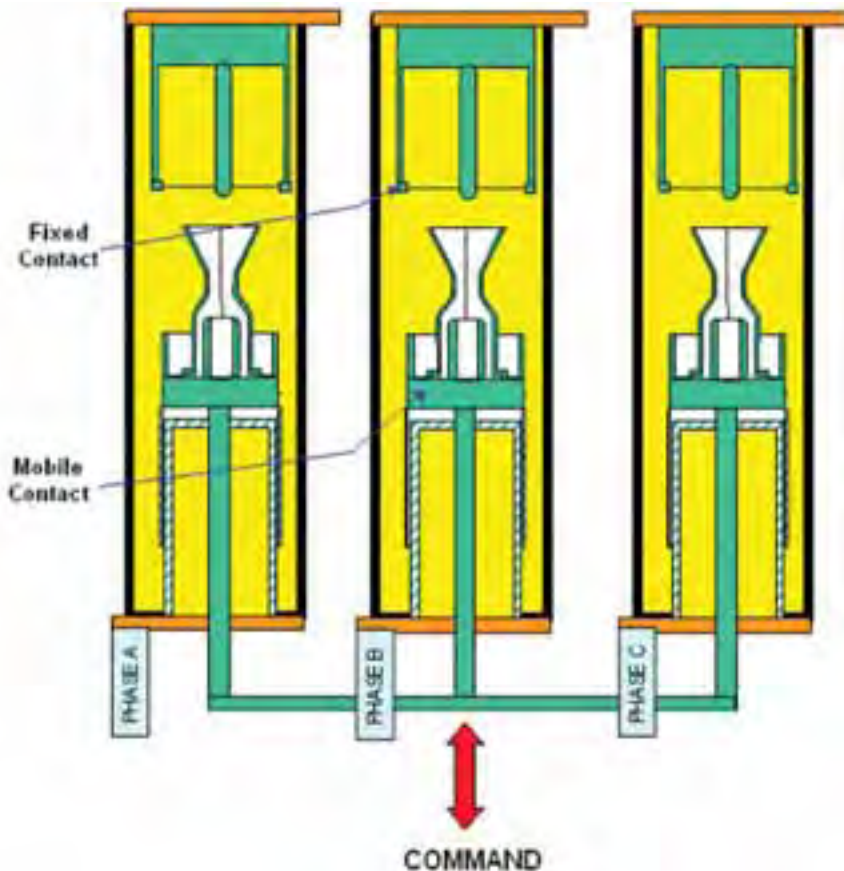

Fig 2.22 - Power section of the circuit breaker

HELP WANTED

Power • Sales • NETA Certified
 Field Service Engs • Techs • Mgrs
 UPS • Design • Vibration • Motor Repair
 Power Quality • Pred/Prev Maint, Etc.

For more than 25 years we've specialized in placing Electrical & Electronic Systems & Service personnel who test, repair, manage, maintain, design or sell electrical and electronic power equipment and electrical apparatus. Nationwide. All fees company paid.

Call or send confidential resume to:
LISA LINEAL LINEAL Recruiting Services

46 Copper Kettle Road, Trumbull, CT 06611
 TOLL FREE 877-386-1091 • Fax: 203-386-9788
 Email: lsalineal@lineal.com • www.lineal.com

Se Habla Español

Fig 2.2.32
- Hydraulic
command

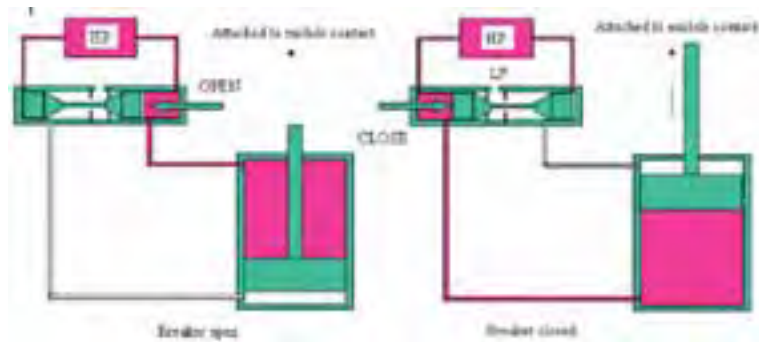

2.2.3.2 Hydraulic command

This type of command has an energy reservoir, or accumulator, either compressed nitrogen or springs compressed by hydraulic fluid and a pump. The moving contact of the circuit breaker is attached to the piston by an insulating rod.

A set of hydraulic valves allows the application of the previously accumulated pressure to one side or the other of the hydraulic ram, which moves it and the contact in the desired direction.

2.2.3.3 Spring-loaded mechanical command

This type is most in demand because of its proven reliability and also because of its very low frequency of periodic maintenance.

It usually consists of two compressed springs, one used to accumulate the energy necessary to close the breaker and the other to store energy to open the breaker.

The closing spring (E) is compressed manually, using a crank, or electrically, using a motor. A locking mechanism holds and controls the energy accumulated in the closing spring.

When this energy is released, by the release of the closing spring, the mobile contact is moved toward the fixed contact, through the connecting rods, while simultaneously charging the opening spring which maintains the energy accumulated with its own locking mechanism, ready to be released on the next opening order.

2.3 Choice of transducers

The goal is to reproduce the exact movement of the moving contact in the breaking chamber of the circuit breaker, which is usually inaccessible because the entire assembly is inside a closed container. While the final displacement of this mobile contact is always linear, the initial movement generated by the command mechanism is not always so.

The movement generated by the command mechanism may be rotary, which is translated into a linear motion by a set of levers and connecting rods.

When the linear movement of the contact is accessible indirectly, for example through the connecting rod, a linear transducer may accurately reproduce this movement by attaching it to the rod in question. In figure 2.3a, you will

continued on page 20

RED DEER

ELECTRICAL LEARNING EXPO

OCTOBER 17, 2006 • WESTERNER PARK PRAIRIE PAVILLION

October 17th, 2006
Red Deer Alberta

SHOW TIME 10:00 – 6:00 / SEMINAR 10:30 – 5:30
Alberta Electrical League's
12th Annual

Don't Miss out!!!

The Electrical Learning EXPO you will see over 100 electrical companies displaying NEW products, NEW innovations, Demonstrating the latest technology.

Featuring; DAY TO DAY Time saving Products.....check out all the products that will save you time and money.

Learning Sessions you won't want to miss

10:30 – 11:30 – **LED Technology** ; Learn about the important advances, trends, applications, do's and don't in a wide range of applications, and more.

12:30 – 1:30 – **Panel Discussion**; Labour force, Manpower issues, Economic project development impact, what government is doing.....get some answers by attending this timely discussion.

1:30 – 2:00 – **Hybrid Technology**; What it is, where it's going and how does it benefit you.

2:00 – 3:00 – **Fluorescent Alternatives to HID highbay lighting** – do's and don't. T5 and T5/HO alternatives, find out why industrial users are switching, energy savings, color rendition and stability. Find out the several pitfalls to unwary user and the advantages.

3:00 – 4:00 – **Grid Connected Solar Power** – Where its at and Where its going. Solar PV overview, National and International Market breakdown, Grid tie Solar overview, New Solar incentive and Demonstration Projects, Current and future market opportunities and more.

4:00 – 4:30 – **Residential Emerging Technologies** – Understand where residential "smart wiring" has been, where it is now and what to expect in the future. Learn about applications, products and methods.

6:30 – 8:30 – **Calling all Master Electricians!!** ECAA and Alberta Munciple Affairs have developed a proposed enhanced Master Electrician Program.

For more information on exhibiting
Or attending please contact:
Alberta Electrical League
Phone (403) 514-3085
Toll Free: (800) 642-5508--
Fax: (403) 514-6169
E-mail: info@eleleague.ab.ca
www.eleleague.ab.ca

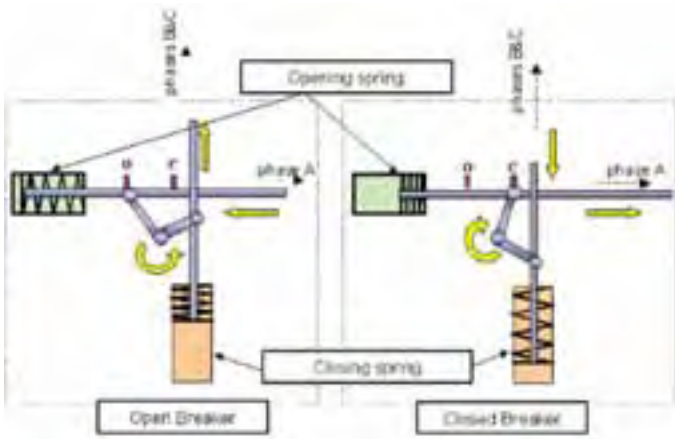

Fig 2.2.33 - Mechanical spring command

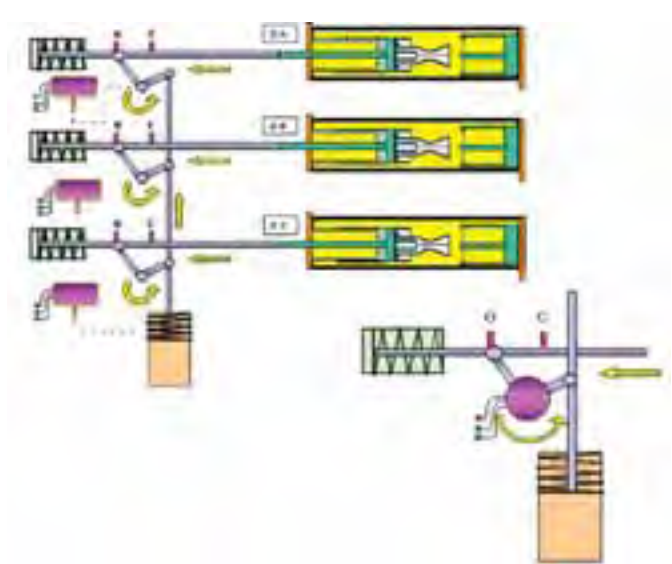
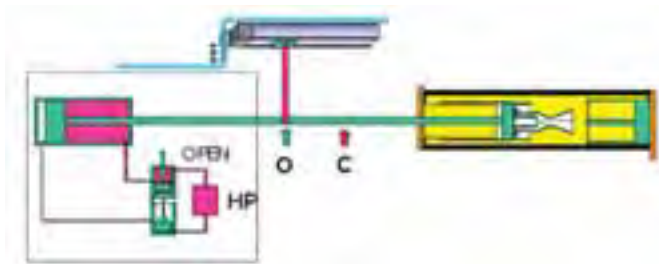
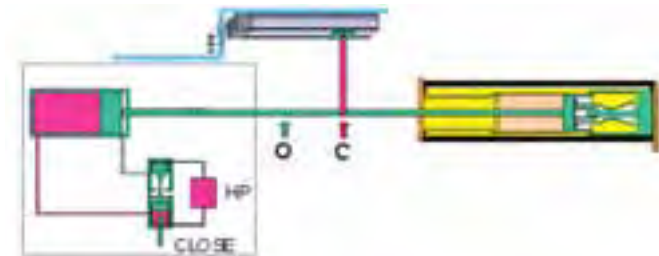

Fig. 2.3b Example using rotary transducers



Linear transducer with breaker in open position



Linear transducer with breaker in closed position
Fig 2.3a Linear transducer examples



Fig. 2.4a Zensol CBA-32P instrument

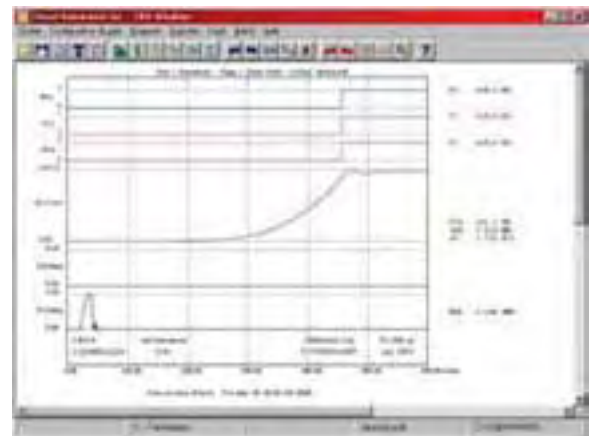

Fig 2.4b CBA Win graphic report as seen on the computer screen

Motion Tests

continued from page 18

find an example of a linear motion sensed by a linear transducer (in the case of an accessible motion).

In the case where only the command motion is accessible, and if this motion is rotary, the final motion of the mobile contact is measured by transforming this rotary motion using various levers and connecting rods of different sizes.

The sizes of the levers add multiplying factors that influence the desired curve, whereas the angular motion of these levers is always the same. In this case, using rotary transducers will give better results.

One condition must be observed, however. A translation curve must be drawn, point-by-point, to convert the angular motion into a linear one.

An example of the use of a rotary transducer is shown in figure 2.3b.

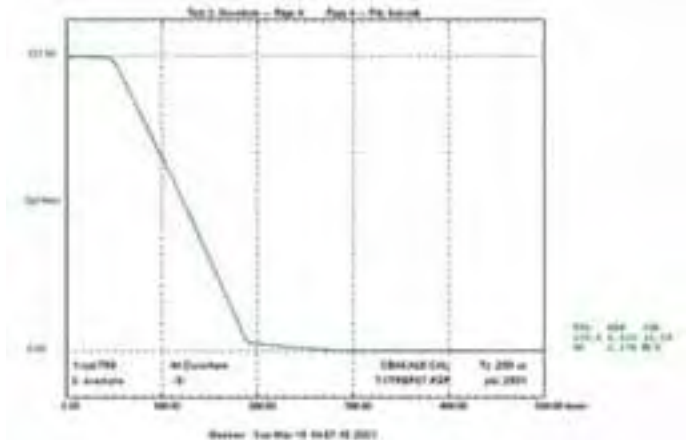
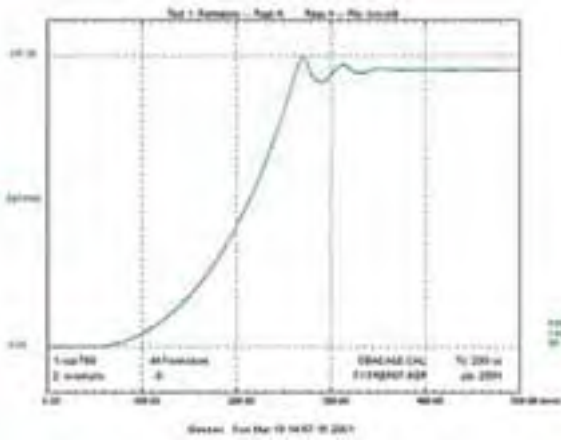

Fig. 2.5 Examples of displacement curves for Close and Open operations

2.4 Acquisition and display of results

The acquisition and the display of the results is performed by the analog input channels of ZENSOL's CBA32P (see Fig. 2.4a)

Each analog channel has three leads numbered (1), (2), and (3) on the corresponding plug.

Between leads (1) and (3), a 10 volt DC signal is generat-

ed during the test. The signal collected from the displacement transducer is measured between (2) and (3), and transmitted to the CBA Win analysis software which draws the curve on the computer screen. Fig. 2.4b shows an example of CBA Win's graphic report, as it is shown on the computer screen.

See the next issue of *Electricity Today* for Part 2

Programma Products

FROM **PROG USA LLC**



EGIL

Easy-to-use CB timing and motion measurements for low and medium voltage Circuit Breakers (Test 3 phase CB's with single interrupter per phase).



ODEN AT

Portable high current source and test system for MCCB's and Primary Current Injection up to 20KA.



MJOLNER 200

NEW, lightweight (19 lbs), 200 AMP micro-ohmmeter with clean, True DC source and two sides grounded testing possible.



SVRKER

Complete protective relay testing toolbox in one very portable instrument.

Ask about our new **TM1800 High End CB Testing System** featuring DRM and new DCM "safe testing" Technologies

CONTINUING TO BE A LEADER IN PORTABLE POWER TESTING EQUIPMENT.

USA 407 332 8678

Toll Free 1 877 PROG USA

Canada 416 674 8970

WWW.PROGUSA.NET