

ATTAINING “ZERO-PACKET-LOSS” IN THE SUBSTATION

By Marzio P. Pozzuoli, RuggedCom Inc. – Industrial Strength Networks

INTRODUCTION

The proliferation of Ethernet networking technology from the office environment to the substation environment for use in real-time mission critical control applications has resulted in both the IEC and IEEE developing new standards addressing networking equipment in substations. In both cases, the standards define conditions that require the networking equipment operate without any loss or interruption of communications during the application of a variety of destructive EMI immunity type tests.

These type tests are essentially the same type tests applied to protective relaying devices and utilize essentially the same test levels. Since the protective relaying devices are required to pass these type tests without ‘misoperation’ or damage, the equivalent is also required of the networking equipment to which these devices are being connected. Zero-Packet-Loss under EMI stress is the networking equivalent of no ‘misoperation’ under EMI stress for protection relays.

This article explores the emerging trends of using the network to perform mission critical real-time control applications, the new IEC and IEEE standards for communications systems and networking equipment in the substation, and the reasons/needs for Zero-Packet-Loss in the substation.

ETHERNET IN THE SUBSTATION – WHY?

Not so very long ago, every major vendor of relays, remote terminal units (RTU), meters and programmable logic controllers (PLC), to name but a few

intelligent electronic devices (IED) used in substations, had their own communications protocol. What this often meant was that most of the IEDs were incompatible even at the physical layer interface as well as the communications protocol layer. Therefore, as was often the case, some sort of protocol converter device was required to bring all of the IEDs onto a common physical network and perform the translation to allow everyone to speak a common application layer protocol. This resulted in expensive integration with often-poor performance because of the insertion of protocol converters.

To remedy these woes, utilities turned to the Electric Power Research Institute (EPRI) and, along with IED manufacturers and leading utilities such as American Electric Power, collaborated to develop the Utility Communications Architecture (UCA2.0) which is the international standard IEC 61850. It provides a set of standards and specifications with a common application layer protocol to ensure everyone speaks the

same language and several communications profiles with Ethernet at the physical layer to ensure everyone resides on the same physical network. This is because Ethernet brings with it a multitude of advantages:

- 10Mbps, 100Mbps, 1Gbps, 10Gbps and growing speeds;
- Support for fiber, copper and wireless media;
- Network redundancy and fault tolerant ring architectures per IEEE 802.1w Rapid Spanning Tree protocol;
- Message Prioritization and Class of Service for real-time control per IEEE 802.1p Priority Queuing;
- Virtual LANs which allows for traffic isolation and system security per IEEE 802.1Q VLAN;
- Deterministic (yes that’s right I said ‘deterministic’) full-duplex operation with no collisions per IEEE 802.3x Flow Control (Modern Ethernet Switches which support IEEE 802.3x do not allow, nor support, nor experience collisions! Collisions are a thing of the past associated with Ethernet networks implement-

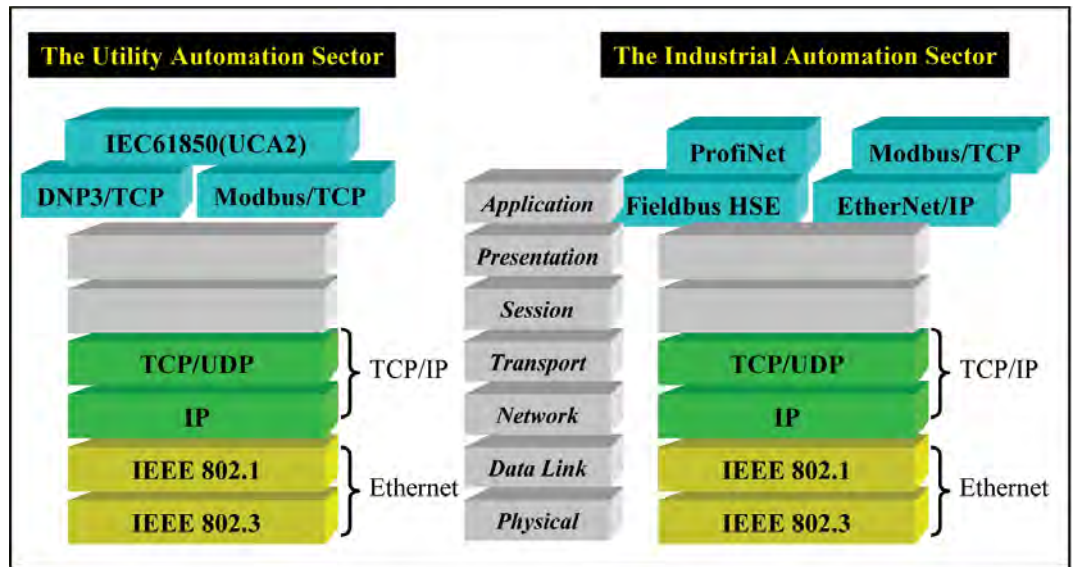

Figure 1: Ethernet based communications profiles in the Utility and Industrial Sectors

UTILITY IEC 61850-3 (61000-6-5) Communications Networks and Systems In Substations (Jan 2002)				
TEST	Description		Test Levels	Severity Levels
IEC 61000-4-2	ESD	Enclosure Contact	+/- 6kV	3
		Enclosure Air	+/- 8kV	3
IEC 61000-4-3	Radiated RFI	Enclosure ports	10 V/m	3
		Signal ports	+/- 4kV @ 2.5kHz	x
IEC 61000-4-4	Burst (Fast Transient)	D.C. Power ports	+/- 4kV	4
		A.C. Power ports	+/- 4kV	4
		Earth ground ports ³	+/- 4kV	4
		Signal ports	+/- 4kV line-to-earth, +/- 2kV line-to-line	4
IEC 61000-4-5	Surge	D.C. Power ports	+/- 2kV line-to-earth, +/- 1kV line-to-line	3
		A.C. Power ports	+/- 4kV line-to-earth, +/- 2kV line-to-line	4
		Signal ports	10V	3
IEC 61000-4-6	Induced (Conducted) RFI	D.C Power ports	10V	3
		A.C. Power ports	10V	3
		Earth ground ports ³	10V	3
		Enclosure ports	40 A/m continuous, 1000 A/m for 1 s	N/A
IEC 61000-4-8	Magnetic Field			
IEC 61000-4-29	Voltage Dips & Interrupts	D.C. Power ports	30% for 0.1s, 60% for 0.1s, 100% for 0.05s	N/A
		A.C. Power ports	30% for 1 period, 60% for 50 periods	N/A
IEC 61000-4-11			100% for 5 periods, 100% for 50 periods ²	N/A
IEC 61000-4-12	Damped Oscillatory	Signal ports	2.5kV common, 1kV differential mode @ 1MHz	3
		D.C. Power ports	2.5kV common, 1kV differential mode @ 1MHz	3
		A.C. Power ports	2.5kV common, 1kV differential mode @ 1MHz	3
IEC 61000-4-16	Mains Frequency Voltage	Signal ports	30V Continuous, 300V for 1s	4
		D.C. Power ports	30V Continuous, 300V for 1s	4
IEC 61000-4-17	Ripple on D.C. Power Supply	D.C. Power ports	10%	3

Table 1: IEC 61850-3 (IEC 61000-6-5) EMI Immunity Type Test Requirements

ed using shared media hubs/repeaters.);

- Ethernet is the world's most widely adopted local area network (LAN) technology and is now migrating into the wide area networking (WAN) space. In the future we could see a total Ethernet solution from the WAN to the MAN (Metropolitan Area Network) to the LAN;

- Every major manufacturer of IEDs (e.g. Relays, RTUs, Meters, PLCs) now provides at least one (some provide dual) Ethernet port on their devices.

In the process control industry (i.e. industrial automation) a similar transformation has taken place with every major vendor of process control IEDs now providing Ethernet connectivity to the degree that many have espoused the notion that "Ethernet is becoming the RS232 for process control..."

NEW STANDARDS COVERING NETWORKS IN SUBSTATIONS

IEC - First Off the Mark

In January 2002, the International Electrotechnical Commission (IEC) released a standard entitled IEC 61850-3 "Communications networks and systems in substations" to specifically address the general environmental and electromagnetic interference (EMI) immunity requirements for network equipment used in substations. In particular, section 5.7 EMI Immunity states that "The general immunity requirements for the industrial environment are considered not sufficient for substations. Therefore, dedicated requirements are defined in IEC 61000-6-5..."

Table 1 above summarizes the possible worst case test levels defined by IEC 61000-6-5 depending on location of the equipment within the substation.

Of critical importance in the IEC 61000-6-5 specification is the performance criteria defined for key functions within the substation. Essentially, it allows for no delays or data loss for

Prevent Transformer Explosion and Fire

The TRANSFORMER PROTECTOR™ prevents the rupture of the transformer tank due to internal faults.

TRANSFORMER PROTECTOR™ Technology:

- Avoids oil fire to transformer and surrounding equipment
- Allows transformer repair after internal fault
- Eliminates the environmental impact by containing the oil
- Eliminates risk to human life

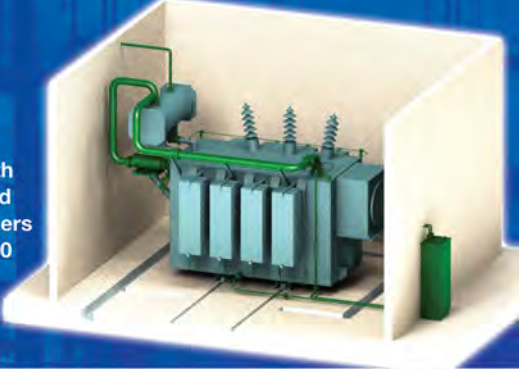

Works with all oil-filled transformers up to 1,000 MVA and more.



For more information call: **281-358-9900**
www.transproco.com / info@transproco.com

IEEE P1613 – Draft Standard Environmental Requirements for Communications Devices Installed in Electric Power Substations				
TEST	Description		Test Levels	Severity Levels
IEEE C37.90.3	ESD	Enclosure Contact	+/- 8kV	N/A
		Enclosure Air	+/- 15kV	N/A
IEEE C37.90.2	Radiated RFI	Enclosure ports	35 V/m	N/A
IEEE C37.90.1	Fast Transient	Signal ports	+/- 4kV @ 2.5kHz	N/A
		D.C. Power ports	+/- 4kV	N/A
		A.C. Power ports	+/- 4kV	N/A
		Earth ground ports ³	+/- 4kV	N/A
IEEE C37.90.1	Oscillatory	Signal ports	2.5kV common mode @ 1MHz	N/A
		D.C. Power ports	2.5kV common & differential mode @ 1MHz	N/A
		A.C. Power ports	2.5kV common & differential mode @ 1MHz	N/A

Table 2: IEEE P1613 EMI Immunity Type Test Requirements

critical functions such as Protection and Teleprotection functions, On-line Processing and Regulation, and Metering when exposed to various EMI phenomena.

IEEE – Following Suit

The Substations Committee of the IEEE Power Engineering Society via the C2TF1 Task Force was also busy producing its own equivalent standard for communications networks in substations entitled IEEE P1613 - “Environmental and Testing Requirements for Communications Networking Devices in Electric Power Substations”. Table 2 summarizes the key EMI immunity requirements defined in the standard.

A key definition in the standard is the definition of two classes of communications devices: Class 1 communications devices allow for communications errors and delays during the application of the required type tests while Class 2 devices allow for no communications errors or delays during the application of the required type tests.

THE ESSENCE OF ZERO-PACKET-LOSS UNDER EMI STRESS

For an Ethernet LAN in the substation the performance requirements of IEC 61850-3 for critical functions and IEEE P1613 Class 2 devices translate to zero-packet-loss under EMI stress which in practical terms means that one must be able to apply all of the EMI type tests listed in Tables 1 & 2 while network traffic through the Ethernet LAN is at its maximum (i.e. 100% frame/packet rate) and experience no frame/packet errors, delays or losses.

This, in essence, guarantees that the LAN equipment has the same level of EMI immunity as the protective relaying IED’s connected to it. Bear in mind that protective relaying IED’s must also pass these very same type tests under simulated operational conditions without any ‘misoperation’ or failures.

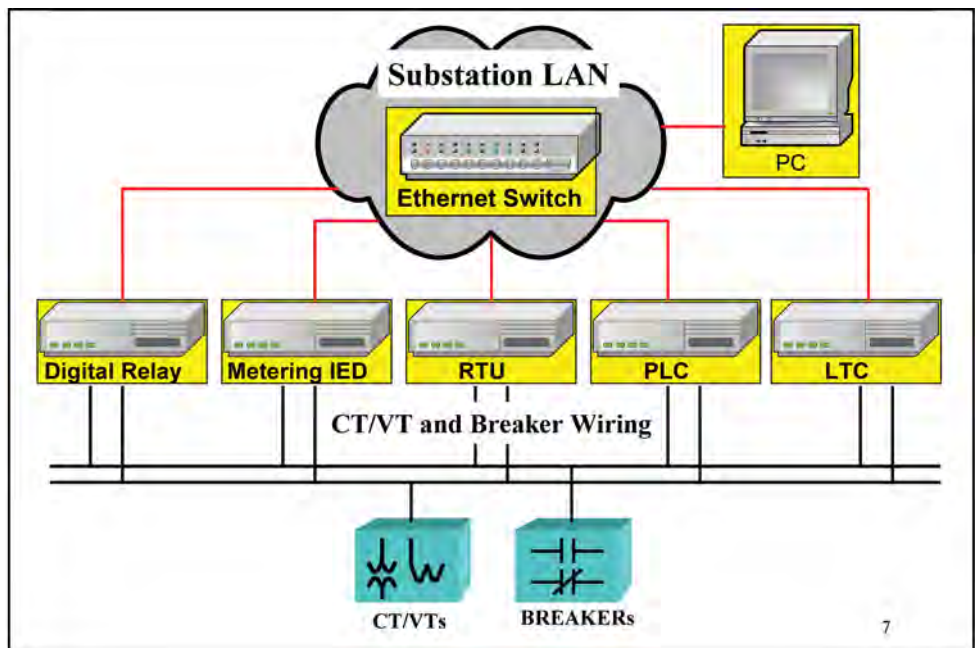

Figure 2: All IED’s connected to a common physical Substation LAN. For the more adventurous; all inter-IED control signaling is done over the Substation LAN.

WHEN IS ZERO-PACKET-LOSS UNDER EMI STRESS NEEDED?

Utilities and vendors alike are no longer simply talking about pilot projects and proof of concept scenarios. In ever-growing numbers, utilities in North America and around the world are deploying substation Ethernet LANs and leveraging them to perform a variety of tasks.

Those who tread cautiously are doing the following:

- IED data collection and monitoring over a high-speed (10/100Mbps) LAN.

- Leveraging the fact that Ethernet LANs allow IEDs supporting different application layer protocols (e.g. Modbus/TCP, DNP3.0, UCA2.0) to coexist harmoniously on a common physical network without protocol converters. This allows one to continue to leverage the investment made in existing protocols and incrementally migrate to a common protocol such as UCA/61850 when there is a sufficient comfort factor.

For this level of performance Zero-Packet-Loss is option-

al.

The more “adventurous” are starting to do the following:

- Relay ‘Trip’ and ‘Block’ signaling via UCA/61850 GOOSE messaging over the LAN;

- Relay Voting Schemes (e.g. 2 out of 3 relays say ‘TRIP’) – where again GOOSE messaging is used over the LAN;

- Bus Blocking/Trip Co-ordination schemes via GOOSE message signaling over the LAN;

- Load shedding and restoration schemes via GOOSE messaging over the LAN.

For this level of performance, and critical functionality of the LAN, Zero-Packet-Loss under EMI is an essential requirement.

The truly “visionary” are looking at:

- A complete LAN-based solution where even the CT/VT wiring and breaker control wiring has been replaced by single IEDs which interface to the CTs and VTs and provide all the current, voltage and other power system parameters over the LAN in a broadcast manner, allowing any or all IEDs connected to the LAN to have access to this information.

- At present, companies such as ABB, Siemens and Alstom have been collaborating and have developed digital CT/VT sensors and breaker IEDs which interface to a 100Mbps Ethernet LAN. This is often referred to in the industry as a “process bus” and is accommodated in sections of soon to be released IEC 61850 specification.

For this level of performance and critical functionality of the LAN, Zero-Packet-Loss under EMI is a must!

CONCLUSIONS

Zero-Packet-Loss performance by networking equipment in the substation environment is essential for current trends to continue.

The basic requirement of having all of the electronic

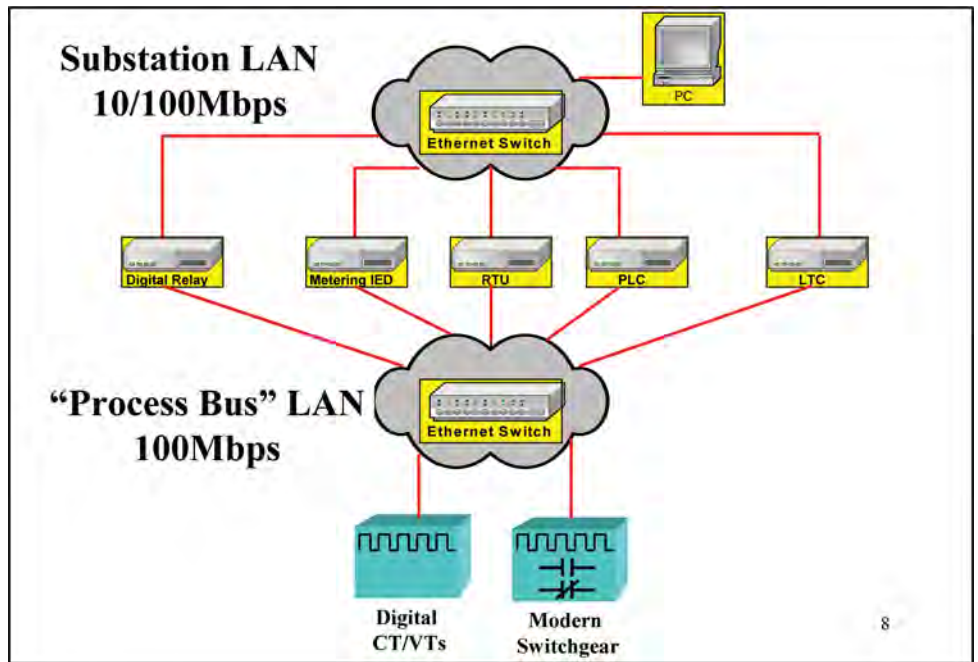

Figure 3: A complete LAN based solution with both IEDs, CT/VTs and Breaker’s connected to Ethernet LANs.

equipment involved in the protection and control system (i.e. Relays, PLCs, and the LAN) capable of passing the same EMI immunity type tests without ‘misoperation’ will give protection and control engineers the confidence to take advantage of the many new possibilities afforded to them by a high-speed LAN based system.

Are you an expert in Arc Flash and Electrical Safety? Your talents are needed NOW!

ELECTRICAL TRAINERS NEEDED

for a variety of subjects:

- Arc Flash Analysis
- Industrial Electrical Safety
- Air Conditioning & Refrigeration
- Short Circuit Study
- Coordination Study
- Arc Flash Study
- Testing and Maintenance
- Electrical Relay Protection
- 2006 Canadian Electrical Code
- Power Transformer Maintenance
- Programmable Logic Controllers
- Variable Frequency Drives
- Test and Measurement Equipment
- Boiler Operation, Maintenance & Safety
- Electrical Ladder Drawings, Schematics & Diagrams
- Generators & Emergency Power Motors, Controls and Starters

If you have considerable working experience in any of these areas AND you have experience in instructing courses in these areas, then send your resume to:

Randolph Hurst, President.
rwh@rogers.com

The Electricity Forum is one of North America's largest Electrical Training organizations. Since 1986, The Electricity Forum has trained more than 25,000 electrical professionals across North America on a wide range of subjects. Our company is seeking experienced electrical training instructors for our public enrollment and on-site training courses. We offer a competitive and innovative package of training fees and expenses.

The Electricity Forum publishes Electricity Today Magazine, Electrical Source Magazine, and 12 Annual Technical Handbooks. Our website at www.electricityforum.com receives more than 10 million page views a year from 1 Million unique visitors.